

FEATURES

- Drives both high-side and low-side MOSFETs in a synchronous buck configuration
- Large drivers designed to drive 6nF server class FETs
 - Low-side driver – 4A source / 6A sink
 - High-side driver – 3A source / 4A sink
 - Transition times & propagation delays < 20ns
- Independent variable gate drive voltage for both high- and low-side drivers from 4.5V to 13.2V
 - Improves efficiency
 - Compatible with IR controller VGD feature
- Integrated bootstrap diode
 - Reduces external component count
- Capable of high switching frequencies from 200kHz up to 1MHz
- Configurable PWM modes of operation
 - IR Active Tri-Level (ATL), disables both MOSFETs in 30ns with no hold-off time
 - Generic Tri-State PWM with hold-off
- Adaptive non-overlap protection minimizes diode conduction time
- Input supply under voltage protection
- Thermally enhanced 10-pin DFN package
- Lead free RoHS compliant package, MSL level 1

APPLICATIONS

- Multiphase synchronous buck converter for Server and desktop computers using Intel® and AMD® VR solutions
- High efficiency and compact VRM
- High current DC/DC converters

DESCRIPTION

The IR3537/CHL8510 is a high efficiency gate driver which can switch both high-side and low-side N-channel external MOSFETs in a synchronous buck converter. It is intended for use with International Rectifier’s Digital PWM controllers to provide a total voltage regulator (VR) solution for today’s advanced computing applications.

The IR3537/CHL8510 low-side driver is capable of rapidly switching large MOSFETs with low $R_{DS(on)}$ and large input capacitance used in high efficiency designs.

The IR3537/CHL8510 features individual control of both the high- and low-side gate drive voltages from 4.5V to 13.2V. This enables the optimization of switching and conduction losses in the external MOSFETs. When used with IR’s proprietary Variable Gate Drive (VGD) technology, a significant improvement in efficiency is observed across the entire load range.

The IR3537/CHL8510 can be configured to drive both the high- and low-side switches from the unique IR fast Active Tri-Level (ATL) PWM signal or a generic tri-state PWM mode. The IR ATL mode allows the controller to disable the high- and low-side FETs in less than 30ns without the need for a dedicated disable pin. This improves VR transient performance, especially during load release.

The integrated bootstrap diode reduces external component count. The IR3537/CHL8510 also features an adaptive non-overlap control for shoot-through protection. This prevents cross conduction of both high-side and low-side MOSFETs and minimizes body diode conduction time to provide the best in class efficiency.

BASIC APPLICATION

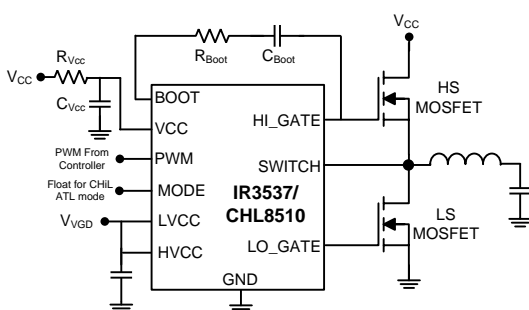

Figure 1: Basic Applications Circuit

PIN DIAGRAM

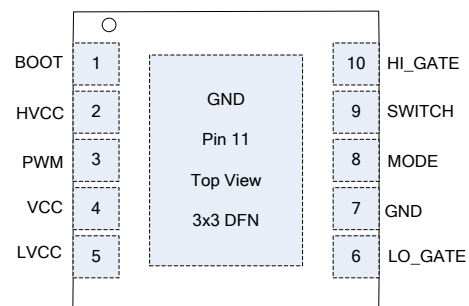
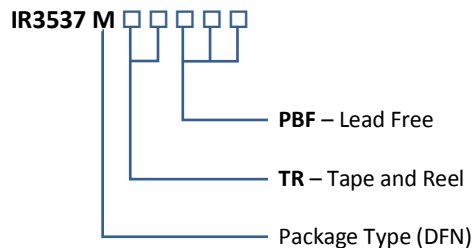
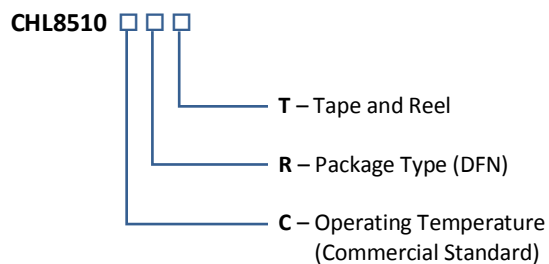

Figure 2: IR3537/CHL8510 Package Top View

ORDERING INFORMATION



Package	Tape & Reel Qty	Part Number
DFN	3000	IR3537MTRPBF
DFN	750	IR3537MTR1PBF



Package	Tape & Reel Qty	Part Number
DFN	3000	CHL8510CRT

FUNCTIONAL BLOCK DIAGRAM

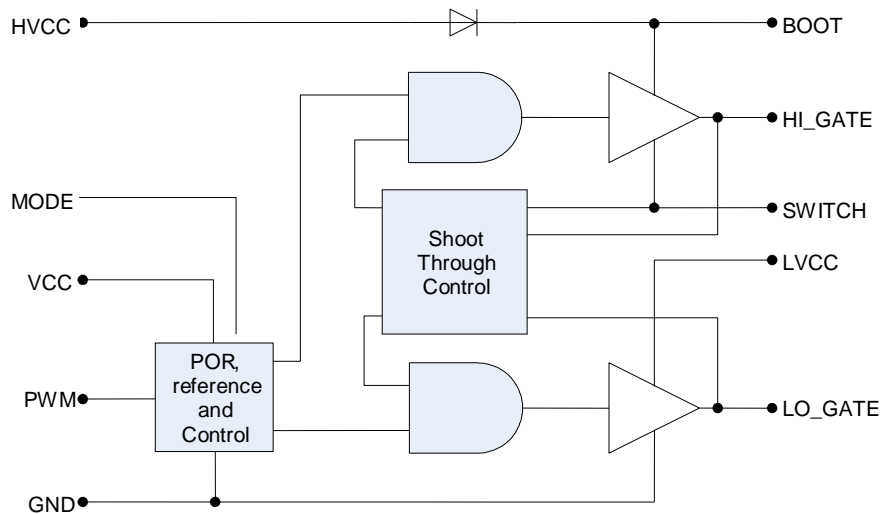

Figure 3: IR3537/CHL8510 Functional Block Diagram

PIN DESCRIPTIONS

PIN #	PIN NAME	PIN DESCRIPTION
1	BOOT	Floating bootstrap supply pin for the upper gate drive. Connect a bootstrap capacitor between this pin and the SWITCH pin. The bootstrap capacitor provides the charge to turn on the upper MOSFET. See the Internal Bootstrap Device section under DESCRIPTION for guidance in choosing the capacitor value.
2	HVCC	Connect this pin to VCC (+12V) or to a separate supply between 4.5V and 13.2V to provide a lower gate drive voltage on the high-side MOSFETs. It is connected to the anode of the internal bootstrap diode. Place a high-quality low ESR ceramic capacitor from this pin to GND.
3	PWM	The PWM signal is the control input for the driver from a 1.8V or 3.3V PWM signal. The PWM signal can enter three distinct states during operation; see the three-state PWM Input section under DESCRIPTION for further details. Connect this pin to the PWM output of the controller.
4	VCC	Connect this pin to a +12V bias supply. Place a high quality low ESR ceramic capacitor from this pin to GND.
5	LVCC	Connect this pin to VCC (+12V) or a separate supply voltage between 4.5V and 13.2V to vary the drive voltage on the low-side MOSFETs. Place a high-quality low ESR ceramic capacitor from this pin to GND. This pin must always be $\leq VCC+0.7Vdc$.
6	LO_GATE	Lower gate drive output. Connect to gate of the low-side power N-Channel MOSFET.
7	GND	Bias and reference ground. All signals are referenced to this node. It is also the power ground return of the driver.
8	MODE	This pin allows selection of the PWM signal voltage for 1.8V or 3.3V normal operation. Floating this pin configures the driver for IR Active Tri-Level (ATL) using 1.8V PWM, and connecting this pin to ground configures the driver for generic active tri-state operation using 3.3V PWM.
9	SWITCH	Connect this pin to the SOURCE of the upper MOSFET and the DRAIN of the lower MOSFET. This pin provides a return path for the upper gate drive.
10	HI_GATE	Upper gate drive output. Connect to gate of high-side power N-Channel MOSFET.
PAD (11)	GND	Bias and reference ground. All signals are referenced to this node. It is also the power ground return of the driver.

TYPICAL APPLICATIONS BLOCK DIAGRAMS

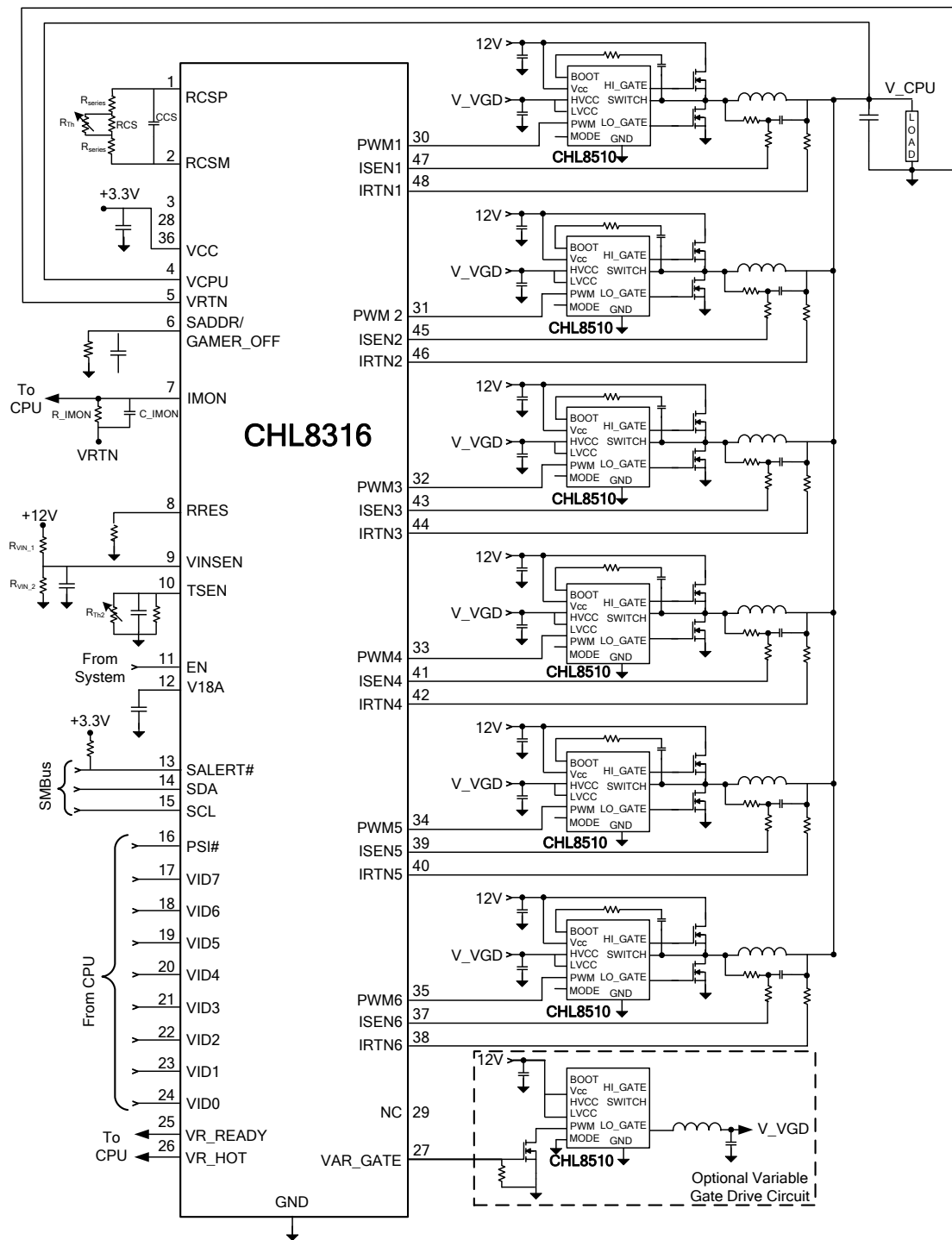

Figure 4: 6-Phase Voltage Regulator using IR3537/CHL8510 MOSFET drivers & CHL8316 Controller

ABSOLUTE MAXIMUM RATINGS

BOOT	+35.0V reference to GND, +15V reference to SWITCH
PWM	+7.0V
VCC, HVCC	+15.0V
LVCC	VCC+0.7Vdc to a maximum of +15.0V
LO_GATE	DC: -0.3V to <0.3V above Vcc, <200ns: -2V to <0.3V above Vcc
GND	0V+/- 0V
SWITCH	DC: -0.3V to +15V, <20nS: 25V, <5nS: -10V, <20 ns: -4Vdc and <200 ns: -2Vdc
HI_GATE	DC: SWITCH – 0.3V to 0.3V above VBOOT, <200ns: SWITCH – 2V to 0.3V above VBOOT
MODE	-0.3V to +15.0V
ESD – Charged Device Model JESD22-C101-C	Passes +/-1000V
THERMAL INFORMATION	
Thermal Resistance (θ_{JC})	3°C/W
Thermal Resistance (θ_{JA}) ¹	45°C/W
Maximum Operating Junction Temperature	150°C
Maximum Storage Temperature Range	-65°C to 150°C
Maximum Lead Temperature (Soldering 10s)	300°C

Note 1: θ_{JA} is measured with the component mounted on a high effective thermal conductivity test board in free air.

Stresses beyond those listed under “Absolute Maximum Ratings” may cause permanent damage to the device. These are stress ratings only and functional operation of the device at these or any other conditions beyond those indicated in the operational sections of the specifications are not implied.

ELECTRICAL SPECIFICATIONS

The electrical characteristics involve the spread of values guaranteed within the recommended operating conditions. Typical values represent the median values, which are related to 25°C.

RECOMMENDED OPERATING CONDITIONS FOR RELIABLE OPERATION WITH MARGIN

Recommended Operating Ambient Temperature	0°C to 85°C
Recommended Operating Junction Temperature	125°C
Recommended Supply Voltage Range	+12V ± 10%
Recommended LVCC & HVCC Range (note LVCC must be ≤Vcc +0.7Vdc)	+4.5V to 13.2V

ELECTRICAL CHARACTERISTICS

PARAMETER	SYMBOL	CONDITIONS	MIN	TYP	MAX	UNIT
Supply						
Supply Bias Current	I_{VCC}	$f_{PWM} = 300kHz$, $V_{VCC} = 12V$, no load	-	7.0	-	mA
Quiescent Bias Current	I_{DD}		-	5.0	-	mA
VCC Rising Threshold for POR			-	8.6	-	V
VCC Falling Threshold for POR			-	7.1	-	V
PWM Input Active Tri-Level Mode (See Figure 5)						
PWM Input High Threshold	$V_{IH(C_PWM)}$	$V_{CC} = 12V$	-	1.0	-	V
PWM Input Low Threshold	$V_{IL(C_PWM)}$	$V_{CC} = 12V$	-	0.8	-	V
PWM Tri-Level Hi Threshold	$V_{TL(C_PWM)}$	$V_{CC} = 12V$	-	2.65	-	V
PWM Tri-Level Low Threshold	$V_{TH(C_PWM)}$	$V_{CC} = 12V$	-	2.55	-	V
PWM Input Current Low	I_{C_PWM}	$V_{pwm} = 0V$	-	-0.88	-	mA
PWM Input Current High		$V_{pwm} = 3.3V$	-	-10	-	μA
PWM Input Tri-State Mode (See Figure 6)						
PWM Input Rising Threshold	$V_{IH(C_PWM)}$	$V_{CC} = 12V$	-	1.65	-	V
PWM Input Falling Threshold	$V_{IL(C_PWM)}$	$V_{CC} = 12V$	-	1.3	-	V
Tri-State LO_GATE Threshold			-	0.85	-	V
Tri-State LO_GATE Hysteresis			-	200	-	mV
Tri-State HI_GATE Threshold			-	2.55	-	V
Tri-State HI_GATE Hysteresis			-	200	-	mV
Tri-State Hold-off Time, Note 1			-	80	-	ns
PWM Input Pull-up Voltage	V_{PWM_pullup}	PWM input floating	-	1.65	-	V
PWM Input Resistance	R_{PWM}	PWM input floating	-	3.75	-	kΩ

High-Side Gate Driver						
Transition Time, Rising, Note 1	$t_{R(HS)}$	6nF Load, $V_{VCC} = 12V$, 10% - 90%	-	21	-	ns
Transition Time, Falling, Note 1	$t_{F(HS)}$	6nF Load, $V_{VCC} = 12V$, 10% - 90%	-	18	-	ns
Transition Time, Rising, Note 1	$t_{R(HS)}$	3nF Load, $V_{VCC} = 12V$, 10% - 90%	-	15	-	ns
Transition Time, Falling, Note 1	$t_{F(HS)}$	3nF Load, $V_{VCC} = 12V$, 10% - 90%	-	12	-	ns
Propagation Delay, Turn-On, Note 1	$t_{PDH(HS)}$	6nF Load, $V_{VCC} = 12V$, Adaptive	-	16	-	ns
Propagation Delay, Turn-Off, Note 1	$t_{PDL(LS)}$	6nF Load, $V_{VCC} = 12V$	-	17	-	ns
Propagation Delay, Exit Tri-State, Note 1	$t_{PDTS(HS_en)}$	6nF Load, $V_{VCC} = 12V$	-	29	-	ns
Propagation Delay, Enter Tri-State, Note 1	$t_{PDTS(HS_dis)}$	6nF Load, $V_{VCC} = 12V$	-	16	-	ns
Source Current, Note 1	I_{HS_SOURCE}	6nF Load, $V_{VCC} = 12V$	-	3.0	-	A
Output Impedance, Sourcing	R_{HS_SOURCE}	Sink Current at 100mA	-	1.6	-	Ω
Sink Current, Note 1	I_{HS_SINK}	6nF Load, $V_{VCC} = 12V$	-	4.0	-	A
Output Impedance, Sinking	R_{HS_SINK}	Sink Current at 100mA	-	0.6	-	Ω
Low-Side Gate Driver						
Transition Time, Rising, Note 1	$t_{F(LS)}$	6nF Load, $V_{VCC} = 12V$, 10% - 90%	-	18	-	ns
Transition Time, Falling, Note 1	$t_{R(LS)}$	6nF Load, $V_{VCC} = 12V$, 10% - 90%	-	13	-	ns
Transition Time, Rising, Note 1	$t_{F(LS)}$	3nF Load, $V_{VCC} = 12V$, 10% - 90%	-	13	-	ns
Transition Time, Falling, Note 1	$t_{R(LS)}$	3nF Load, $V_{VCC} = 12V$, 10% - 90%	-	9	-	ns
Propagation Delay, Turn-On, Note 1	$t_{PDH(LS)}$	6nF Load, $V_{VCC} = 12V$, Adaptive	-	17	-	ns
Propagation Delay, Turn-Off, Note 1	$t_{PDL(LS)}$	6nF Load, $V_{VCC} = 12V$	-	13	-	ns
Propagation Delay, Exit Tri-State, Note 1	$t_{PDTS(LS_en)}$	6nF Load, $V_{VCC} = 12V$	-	26	-	ns
Propagation Delay, Enter Tri-State, Note 1	$t_{PDTS(LS_dis)}$	6nF Load, $V_{VCC} = 12V$	-	14	-	ns
Source Current, Note 1	I_{LS_SOURCE}	6nF Load, $V_{VCC} = 12V$	-	4.0	-	A
Output Impedance, Sourcing	R_{LS_SOURCE}	Sink Current at 100mA	-	1.5	-	Ω
Sink Current, Note 1	I_{LS_SINK}	6nF Load, $V_{VCC} = 12V$	-	6	-	A
Output Impedance, Sinking	R_{LS_SINK}	Sink Current at 100mA	-	0.4	-	Ω

Note 1: Guaranteed by design but not tested in production.

TIMING DIAGRAMS

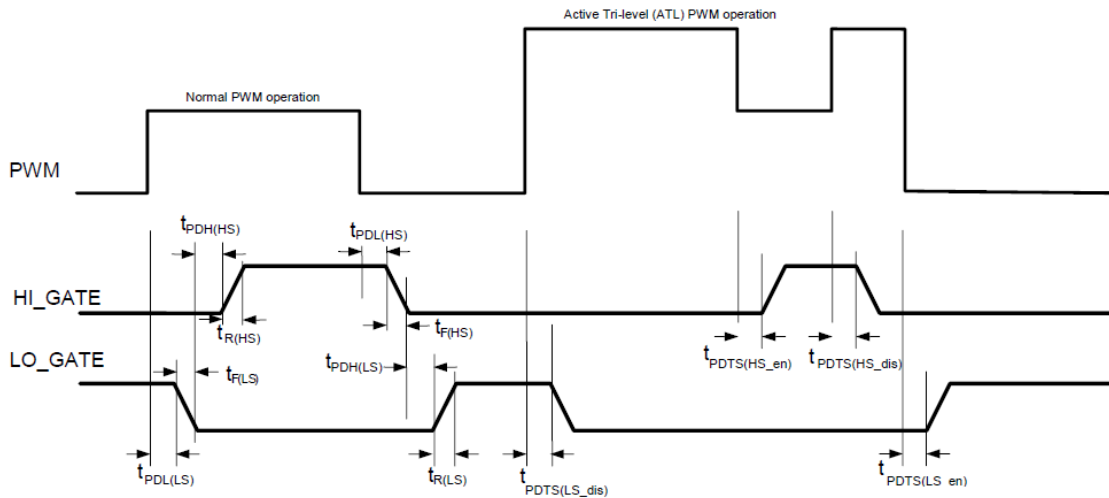

Figure 5: Active Tri-Level Mode PWM, HI_GATE and LO_GATE Signals

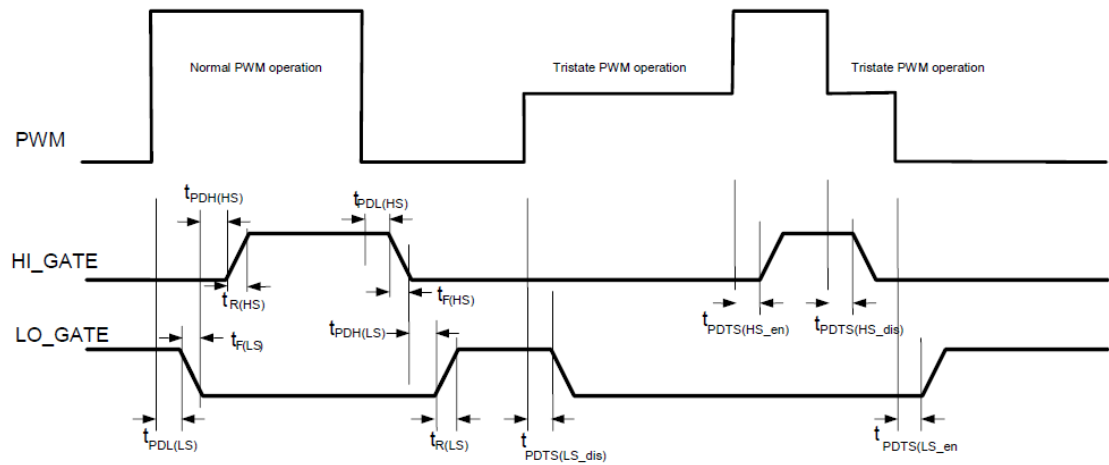

Figure 6: Tri-State Mode PWM, HI_GATE and LO_GATE Signals

GENERAL DESCRIPTION

The IR3537/CHL8510 is a high efficiency, fast MOSFET driver with large source and sink current capability. It can reliably drive the external high- and low-side N-channel MOSFETs with large input capacitance at switching frequencies up to 1MHz. The proprietary IR Active Tri-Level (ATL) feature allows complete control over enable and disable of both MOSFETs using the PWM input signal from the controller. The driver is also compatible with a generic tri-state PWM signal. The Active Tri-Level or tri-state is selectable by the MODE pin.

During normal operation the PWM transitions between low and high voltage levels to drive the low- and high-side MOSFETs. The PWM signal falling edge transition to a low voltage threshold initiates the high-side driver turn off after a short propagation delay, $t_{PD(LHS)}$. The dead time control circuit monitors the HI_GATE and switch voltages to ensure the high-side MOSFET is turned off before the LO_GATE voltage is allowed to rise to turn on the low-side MOSFET.

The PWM rising edge transition through the high-side turn-on threshold initiates the turn off of the low-side MOSFET after a small propagation delay, $t_{PD(LS)}$. The adaptive dead time circuit provides the appropriate dead time by determining if the falling LO_GATE voltage threshold has been crossed before allowing the HI_GATE voltage to rise and turn on the high-side MOSFET, $t_{PD(HS)}$.

THEORY OF OPERATION

POWER-ON RESET (POR)

The IR3537/CHL8510 incorporates a power-on reset feature. This ensures that both the high- and low-side output drivers are made active only after the device supply voltage has exceeded a certain minimum operating threshold. The Vcc supply is monitored and both the drivers are set to the low state, holding both external MOSFETs off. Once Vcc crosses the rising POR threshold, the IR3537/CHL8510 is reset and the outputs are held in the low state until a transition from tri-state to active operation is detected at the PWM input. During normal operation the drivers continue to remain active until the Vcc falls below the falling POR threshold.

These POR voltage threshold levels allow seamless functionality with International Rectifier's digital controllers, such that the drivers are always active before the controller starts to provide the PWM signal and are inactive only after the controller shuts down.

INTEGRATED BOOTSTRAP DIODE

The IR3537/CHL8510 features an integrated bootstrap diode to reduce external component count. This enables the IR3537/CHL8510 to be used effectively in cost and space sensitive designs.

The bootstrap circuit is used to establish the gate voltage for the high-side driver. It consists of a diode and capacitor connected between the SWITCH and BOOT pins of the device. Integrating the diode within the IR3537/CHL8510, results in the need for an external boot capacitor only. The bootstrap capacitor is charged through the diode and injects this charge into the high-side MOSFET input capacitance when PWM signal goes high.

PWM MODE SELECTION

The IR3537/CHL8510 features a MODE pin which allows operation with different PWM signal levels. The IR3537/CHL8510 is capable of driving external MOSFETs based on one of two different tri-level PWM input signals from a controller.

Floating the MODE pin enables the IR3537/CHL8510 to switch external FETs based on the IR Active Tri-Level mode. In ATL mode, the PWM voltage level is from 0V to 1.8V for low to high transitions. A PWM voltage level greater than the tri-state HI_GATE threshold disables switching of both MOSFETs. Grounding the MODE pin enables the

IR3537/CHL8510 to switch FETs based on a generic tri-state signaling with the PWM signal from 0V to 3.3V for low to high transitions. A PWM voltage level in the tri-state window between 1.23V and 1.82V for 80ns results in disabling both external MOSFETs.

IR ACTIVE TRI-LEVEL PWM INPUT SIGNAL

The IR3537/CHL8510 gate drivers are driven by a unique tri-level PWM control signal provided by the International Rectifier's digital PWM controllers. During normal operation, the rising and falling edges of the PWM signal transitions between 0V and 1.8V to switch the LO_GATE and HI_GATE. To force both driver outputs low simultaneously, the PWM signal crosses a tri-state voltage level higher than the tri-state HI_GATE threshold. This threshold based tri-state results in a very fast disable with only a small tri-state propagation delay. MOSFET switching resumes when the PWM signal falls below the tri-state threshold into the normal operating voltage range.

This fast tri-state operation eliminates the need for the PWM signal to dwell in the shutdown window, eliminating any hold-off time. In addition, the disable delay time is not affected by the PWM trace routing capacitance. A dedicated enable pin is not required which simplifies the routing and layout in applications with a limited number of board layers. It also provides switching free of shoot through for PWM transition times of up to 20ns. The IR3537/CHL8510 is therefore tolerant of stray capacitance on the PWM signal lines.

The IR3537/CHL8510 provides a 0.88mA typical pull-up current to drive the PWM input to the tri-state condition of 3.3V when the PWM controller output is in its high impedance state. The 0.88mA typical current is designed for driving worst case stray capacitances and transition the IR3537/CHL8510 into the tri-state condition rapidly to avoid a prolonged period of conduction of the high- or low-side MOSFETs during faults. Once the PWM signal has been pulled up, the current is disabled to reduce power consumption.

DIODE EMULATION DURING LOAD RELEASE

One advantage of ATL is the ability to quickly turn-off all low-side MOSFETs during a load release event. This is known as diode emulation since all the load current is forced to flow momentarily through the body diodes of the MOSFETs. This results in a much lower overshoot on the output voltage as can be seen in Figure 7.

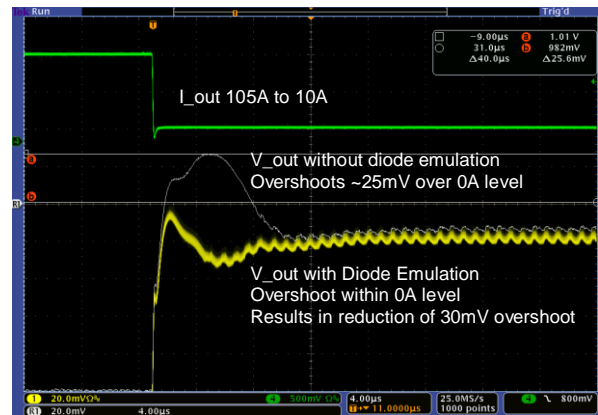

Figure 7: Output voltage overshoot reduction with body-braking

START UP

During initial startup, the IR3537/CHL8510 holds both high- and low-side drivers low even after POR threshold is reached. This mode is maintained while the PWM signal is pulled to the tri-state threshold level greater than the tri-state HI_GATE threshold and until it transitions out of tri-state. It is this initial transition out of the tri-state which enables both drivers to switch based on the normal PWM voltage levels.

This startup also ensures that any undetermined PWM signal levels from a controller in pre-POR state will not result in high or low-side MOSFET turn on until the controller is out of its POR.

Note: The CHL8510/IR3537 driver requires that the LVCC and VCC supply voltages be sequenced and operated under all start-up, operating, and shutdown conditions such that Vcc is always greater than LVCC -0.7Vdc. Failure to do this properly can cause catastrophic damage to the CHL8510/IR3537 driver.

HIGH-SIDE DRIVER

The high-side driver drives an external floating N-channel MOSFET which can be switched at up to 1MHz. An external bootstrap circuit referenced to the SWITCH node, consisting of a boot diode and capacitor is used to bias the external MOSFET gate. When the SWITCH node is at ground, the boot capacitor is charged to the voltage on the HVCC pin less the forward drop of the diode. This stored charge is used to turn on the high-side MOSFET when the PWM signal goes high. Once the high-side MOSFET is turned on, the SWITCH voltage is raised to the supply voltage, and the BOOT voltage is equal to the

supply voltage plus the HVCC voltage less the diode forward voltage.

When the PWM signal goes low, the MOSFET is turned off by pulling the MOSFET gate to the SWITCH voltage.

LOW-SIDE DRIVER

The IR3537/CHL8510 low-side driver is designed to drive an external N-channel MOSFET referenced to ground at up to 1MHz. The low-side driver is connected internally to the LVCC supply voltage.

ADAPTIVE DEAD TIME ADJUSTMENT

In a synchronous buck configuration, dead time between the turn off of one gate and turn on of the other is necessary to prevent simultaneous conduction of the external MOSFETs preventing a shoot-through condition which would result in a short of the supply voltage to ground. A fixed dead time does not provide optimal performance across a variety of MOSFETs and board layouts.

The IR3537/CHL8510 provides an 'adaptive' dead time adjustment. This feature minimizes dead time which maximizes efficiency. The 'break before make' adaptive design is achieved by monitoring gate and SWITCH voltages to determine OFF status of a MOSFET. It also provides zero-voltage switching (ZVS) of the low-side MOSFET with minimum current conduction through its body-diode.

When the PWM is switching between 1.8V and 0V, its falling edge transition from high to low will turn off the high-side gate driver. The adaptive dead time circuit monitors the HI_GATE and the SWITCH node voltages during the high-side MOSFET turn off. When the HI_GATE falls below 1.7V above the SWITCH node potential or the SWITCH node voltage drops below 0.8V, the high-side MOSFET is determined to be turned off, and the LO_GATE turn-on is initiated. This turns on the external low-side MOSFET. The rising edge transition of the PWM signal from low to high voltage causes the low-side gate driver to turn off. The adaptive circuit monitors the voltage at LO_GATE and when it falls below 1.7V, the low-side MOSFET is turned off, and the high-side MOSFET turn-on is initiated. This turns on the external high-side MOSFET.

INDEPENDENT VARIABLE GATE VOLTAGE

The IR3537/CHL8510 features independent variable gate voltages for both the high- and low-side drivers. This enables implementation of the Variable Gate Drive (VGD) feature in VR circuits using the IR multiphase controllers to improve efficiency.

The voltage applied to the HVCC and LVCC pins of IR3537/CHL8510 determines the gate voltage on the external MOSFETs. These pins may be powered from independent voltage sources or tied together to a common voltage source. Variation in the gate voltage allows efficiency to be optimized across the load current range by trading off conduction and switching losses. Increasing the voltage across a MOSFET gate, results in reduced $R_{ds(on)}$ which lowers the MOSFET conduction losses, but also raises the gate charge which increases the switching losses. The voltage on each HVCC and LVCC pin, and thus the gate drive voltage of the CHL8510, can be varied from 4.5V to 13.2V.

The International Rectifier's digital multiphase controllers provide a unique VAR_GATE output which varies inversely with the VR output current. The VAR_GATE output is designed to be used with an external circuit and provide the optimum voltage across the IR3537/CHL8510's HVCC and LVCC pins for optimum system efficiency across the load range.

APPLICATION INFORMATION

Figure 1 shows the typical applications circuit for the IR3537/CHL8510.

BOOTSTRAP CIRCUIT

Once the high-side MOSFET selection is made, the bootstrap circuit can be defined. The integrated boot diode of the IR3537/CHL8510 reduces the external component count in cost and space sensitive designs. For ultra high efficiency designs, an external bootstrap diode is recommended.

The bootstrap capacitor C_{BOOT} stores the charge and provides the voltage required to drive the external high-side MOSFET gate. The minimum capacitor value can be defined by:

$$C_{BOOT} = Q_{HS_MOSFET_GATE} / \Delta V_{BOOT}$$

Where,

- $Q_{HS_MOSFET_GATE}$ is the total gate charge of the high-side external MOSFET(s)
- ΔV_{BOOT} is the droop allowed on the bootstrap capacitor voltage (at the high-side MOSFET gate)

If an external bootstrap diode is used, D_{BOOT} must be capable of handling the average and peak currents, I_{D_AVG} and I_{D_PEAK} , and also the maximum supply voltage.

$$I_{D_AVG} = Q_{HS_MOSFET_GATE} \times F_{SW_MAX}$$

Where,

- F_{SW_MAX} is the controller's maximum switching frequency. The I_{D_PEAK} rating of the diode is determined by actual circuit measurements.

The I_{D_peak} rating of the diode is determined by actual circuit measurements.

A series resistor (R_{BOOT}) of 1Ω to 4Ω, is added to limit the surge current into the boot capacitor on start-up. This resistor can also be used to set the rising slew rate of the high-side MOSFET gate drive (HI_GATE) to help slow the rise time of the switch node for reduced ringing.

SUPPLY DECOUPLING CAPACITOR

Decoupling to the IR3537/CHL8510 is provided by a bypass capacitor C_{VCC} located close to the supply input pin. A 1μF, low ESR, multilayer ceramic capacitor is recommended. A series resistor R_{VCC} , typically 10Ω, is added in series with the supply voltage to filter high frequency ringing and noise.

PCB LAYOUT CONSIDERATIONS

PCB layout and design is important to driver performance in voltage regulator circuits due to the high current slew rate (di/dt) during MOSFET switching.

- Locate all power components in each phase as close to each other as practically possible in order to minimize parasitics and losses, allowing for reasonable airflow.
- Input supply decoupling and bootstrap capacitors should be physically close to their respective IC pins.
- High current paths like the gate driver traces should be as wide and short as practically possible.
- Trace inductances to the high- and low-side MOSFETs should be minimized.
- The ground connection of the IC should be as close as possible to the low-side MOSFET source.
- Use of a copper plane under and around the IC and thermal vias connected to buried copper layers improves the thermal performance.

MARKING INFORMATION

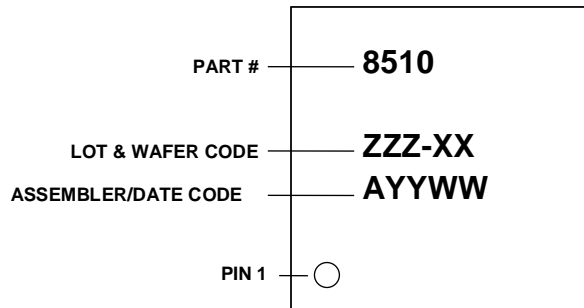

Figure 8: Marking Information for CHL8510

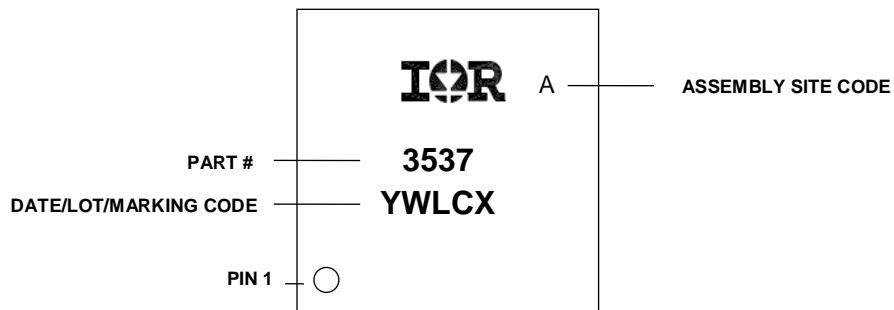

Figure 9: Marking Information for IR3537

PACKAGE INFORMATION

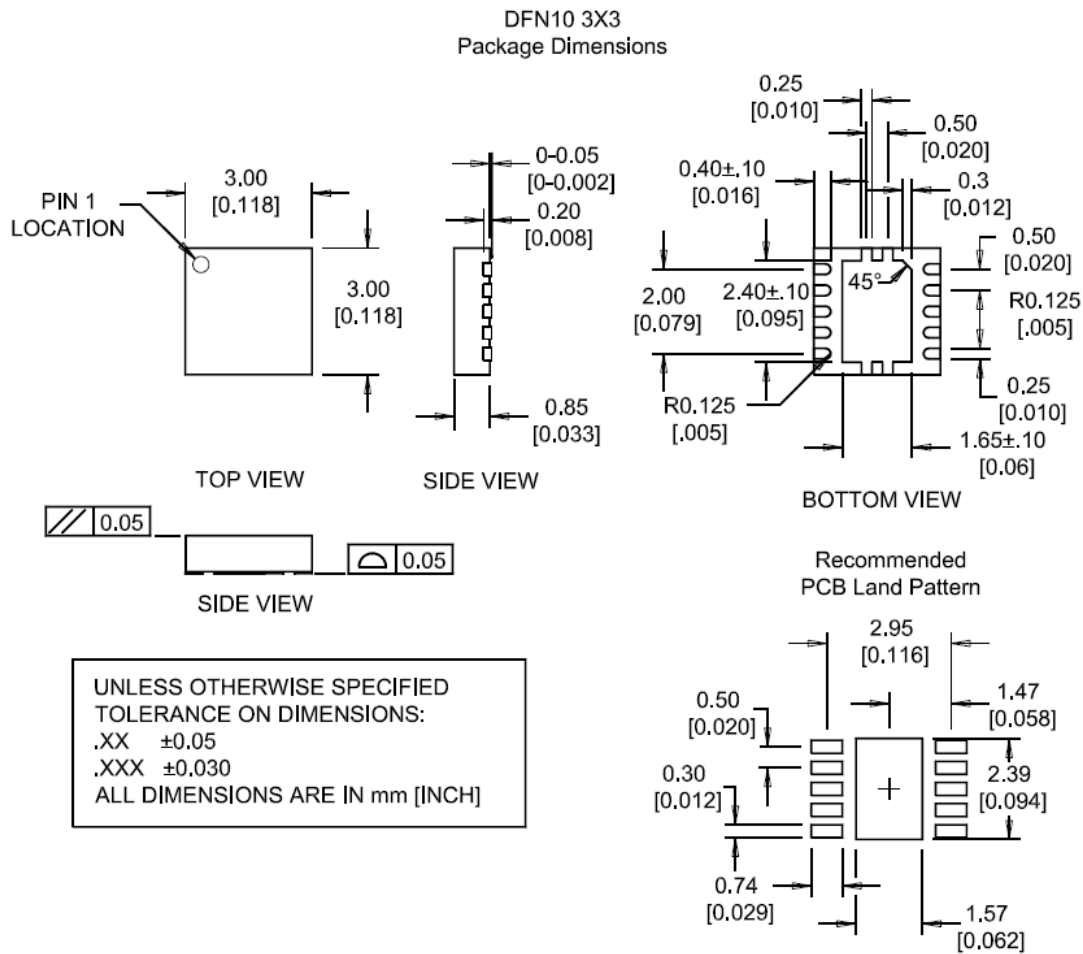

Figure 10: DFN 3x3mm, 10-pin

Data and specifications subject to change without notice.
This product will be designed and qualified for the Consumer market.
Qualification Standards can be found on IR's Web site.

International
IR Rectifier

IR WORLD HEADQUARTERS: 233 Kansas St., El Segundo, California 90245, USA Tel: (310) 252-7105
TAC Fax: (310) 252-7903

Visit us at www.irf.com for sales contact information.
www.irf.com